

TRIUMPH



Tire Selector

Information

Warning

Use the recommended tires ONLY in the combinations given. Do not mix tires from different manufacturers as this may result in loss of motorcycle control and an accident.

MODEL	MODEL YEAR	MANUFACTURER	FRONT TIRE	SPECIFICATION	SIZE	PRESSURE	REAR TIRE	SPECIFICATION	SIZE	PRESSURE
✓ TIGER SPORT (FROM VIN 570059)	2013 ON	PIRELLI METZELER DUNLOP MICHELIN	ANGEL ST ROADTEC 28 INTERACT ROADSMART PILOT ROAD 3	A STANDARD STANDARD STANDARD	120/70/ZR17 58 W 120/70/ZR17 58 W 120/70/ZR17 58 W 120/70/ZR17 58 W	2.34 bar (34 lb/in ²)	ANGEL ST PILOT ROAD 3 ROADSMART PILOT ROAD 3	STANDARD STANDARD STANDARD STANDARD	180/55/ZR17 73 W 180/55/ZR17 73 W 180/55/ZR17 73 W 180/55/ZR17 73 W	2.90 bar (42 lb/in ²)
✗ TIGER SPORT (FROM VIN 570059)	2013 ON	PIRELLI METZELER DUNLOP MICHELIN	ANGEL ST ROADTEC 28 INTERACT ROADSMART PILOT ROAD 3	A STANDARD STANDARD STANDARD	120/70/ZR17 58 W 120/70/ZR17 58 W 120/70/ZR17 58 W 120/70/ZR17 58 W	2.34 bar (34 lb/in ²)	ANGEL ST PILOT ROAD 3 ROADSMART PILOT ROAD 3	STANDARD STANDARD STANDARD STANDARD	180/55/ZR17 73 W 180/55/ZR17 73 W 180/55/ZR17 73 W 180/55/ZR17 73 W	2.90 bar (42 lb/in ²)

Warning

The use of off road tires will result in reduced motorcycle stability. Always operate a motorcycle equipped with off road tires at reduced speeds. The permissible maximum speed is specified for off road tires in this publication. Operation of the motorcycle above the permissible maximum speed may result in loss of motorcycle control and an accident.

Note:

The tires listed in this tire selector are correct at the time of publication for motorcycles in current production only. Tires for motorcycles no longer in production are listed for information purposes only and were correct only at the time production ceased.

Triumph Motorcycles Limited reserves the right to list an alternative tire for any motorcycle at any time, but has no such obligation to list alternatives where production of a motorcycle or tire has ceased. Tire production for any tire listed may cease at any time and is beyond Triumph Motorcycles Limited control. Inclusion of a tire in this tire selector is not a guarantee of tire availability.

No liability can be accepted for any inaccuracies or omissions in this publication, although every possible care has been taken to make it as complete and accurate as possible.

Tire Marking Guide

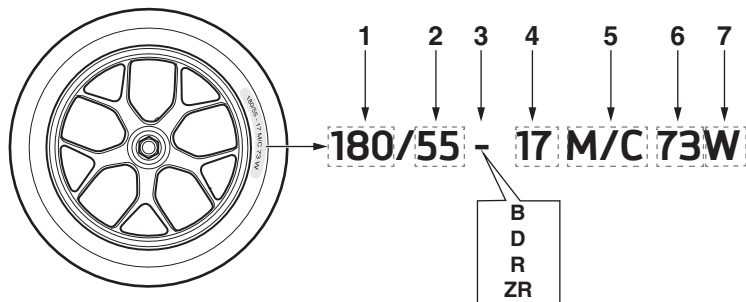

- Nominal section width (mm).
- Aspect Ratio (Defines the section height as a percentage of width. i.e 180x55% = 99 mm).
- Construction type:
 - B refers to a bias belted construction
 - or D refers to a diagonal ply (historically cross ply)
 - R refers to a radial construction
 - ZR refers to a radial tire capable of over 149 mph (240 km/h).
- Rim diameter in inches.
- Denotes a motorcycle tire.
- Load rating.
- Speed rating.

Adventure



Classics



Cruisers



Roadsters



Supersports



Touring



Index

Adventure

Index

MODEL	MODEL YEAR	MANUFACTURER	FRONT TIRE	SPECIFICATION	SIZE	PRESSURE	REAR TIRE	SPECIFICATION	SIZE	PRESSURE
TIGER 855	1993 ON 1993 TO 1994 1994 ON 1995 ON	MICHELIN PIRELLI DUNLOP BRIDGESTONE	T66X MT60 TRAILMAX TRAIL WING 101		110/80-19 100/90-19 100/90-19 110/90-19	2.07 bar (30 lb/in ²)	T66X MT60 TRAILMAX TRAIL WING 152		140/80-17 140/80-17 140/80-17 140/80-17	2.28 bar (33 lb/in ²)
TIGER 855	1995 ON 1996 ON 1996 ON	PIRELLI METZELER PIRELLI	MT60R ENDURO 4 MT80R		110/80-19 110/80-19 110/80-19	2.07 bar (30 lb/in ²)	MT80RS ENDURO 4 MT80R		140/80-17 140/80-17 140/80-17	2.28 bar (33 lb/in ²)
TIGER 855i (FROM VIN 71699 UP TO VIN 124105)	1999 ON	MICHELIN METZELER	T66X ENDURO 4		110/80-19 110/80-19	2.48 bar (36 lb/in ²)	T66X ENDURO 4		150/70-17 150/70-17	2.90 bar (42 lb/in ²)
TIGER 955i (FROM VIN 124106 UP TO VIN 198874)	2001 TO 2004 2001 TO 2004 2001 TO 2004 2001 TO 2004	METZELER PIRELLI MICHELIN BRIDGESTONE	TOURANCE MT90 T66X TRAIL WING 101 RADIAL		110/80/R19 59 V 110/80-19 110/80-19 110/80-19	2.48 bar (36 lb/in ²)	TOURANCE MT90 T66X TRAIL WING 101 RADIAL		150/70/R17 69 V 150/70-17 150/70-17 150/70-17	2.90 bar (42 lb/in ²)
TIGER 955i (FROM VIN 198875 UP TO VIN 287503)	2004 ON 2004 ON	MICHELIN BRIDGESTONE	ANAKEE RADIAL TRAIL WING 101 RADIAL		110/80/R19 59 V 110/80/R19 59 V	2.48 bar (36 lb/in ²)	ANAKEE RADIAL TRAIL WING 152 RADIAL		150/70-17 150/70-17	2.90 bar (42 lb/in ²)
TIGER 1050 CC INCLUDING ABS (FROM VIN 287504 UP TO VIN 570058)	2007 TO 2013 2008 TO 2013	MICHELIN BRIDGESTONE	PILOT ROAD S BATTLAX BT-021	STANDARD L	120/70/ZR17 58 W 120/70/ZR17 58 W	2.34 bar (34 lb/in ²)	PILOT ROAD S BATTLAX BT-021	STANDARD L	180/55/ZR17 73 W 180/55/ZR17 73 W	2.90 bar (42 lb/in ²)
TIGER 800 *FRONT TIRE SIZE 110/80/R19 M/C 59 V MAY BE USED IN MARKETS WHERE THE RECOMMENDED SIZE (100/90-19 M/C 57 V) IS NOT AVAILABLE.	2011 ON	PIRELLI *PIRELLI METZELER *METZELER MICHELIN *MICHELIN	SCORPION TRAIL *SCORPION TRAIL TOURANCE EXP *TOURANCE EXP ANAKEE 3 *ANAKEE 3	STANDARD STANDARD STANDARD STANDARD STANDARD STANDARD	100/90-19 57 V *110/80/R19 59 V 100/90-19 57 H *110/80/R19 59 V 100/90-19 57 V *110/80/R19 59 V	2.48 bar (36 lb/in ²)	SCORPION TRAIL SCORPION TRAIL TOURANCE EXP TOURANCE EXP ANAKEE 3 ANAKEE 3	G G N STANDARD STANDARD STANDARD	150/70/R17 69 V 150/70/R17 69 V 150/70/R17 69 V 150/70/R17 69 V 150/70/R17 69 V 150/70/R17 69 V	2.90 bar (42 lb/in ²)
TIGER 800XC	2011 ON	PIRELLI BRIDGESTONE MICHELIN	SCORPION TRAIL BATTLE WING BW-501 ANAKEE 3	STANDARD G STANDARD	90/90-21 54 V 90/90-21 54 V 90/90-21 54 V	2.48 bar (36 lb/in ²)	SCORPION TRAIL BATTLE WING BW-502 ANAKEE 3	STANDARD STANDARD STANDARD	150/70/R17 69 V 150/70/R17 69 V 150/70/R17 69 V	2.90 bar (42 lb/in ²)
TIGER 800XC DUAL PURPOSE TIRES (APPROVED BY TRIUMPH FOR OFF ROAD AND ON ROAD USE IN SOME COUNTRIES ONLY). THE PERMISSABLE MAXIMUM SPEED FOR DUAL PURPOSE TIRES IS 60 MPH (96 KM/H).	2011 ON	METZELER	MCE KAROO 2(T)	STANDARD	90/90-21 54 Q	1.50 bar (22 lb/in ²)	MCE KAROO (T)	STANDARD	150/70/R17 69 Q	1.50 bar (22 lb/in ²)

Continued...

Adventure (continued)

Index

MODEL	MODEL YEAR	MANUFACTURER	FRONT TIRE	SPECIFICATION	SIZE	PRESSURE	REAR TIRE	SPECIFICATION	SIZE	PRESSURE
TIGER XR, TIGER XRt, TIGER XRx **TYRES RECOMMENDED AND APPROVED FOR USE WITH EXPEDITION ALUMINIUM LUGGAGE SYSTEM.	2015 ON	**METZELER PIRELLI	**TOURANCE NEXT SCORPION TRAIL	**STANDARD STANDARD	100/90-19 57 V 100/90-19 57 V	2.48 bar (36 lb/in ²)	**TOURANCE NEXT SCORPION TRAIL	**STANDARD STANDARD	150/70/R17 69 V 150/70/R17 69 V	2.90 bar (42 lb/in ²)
TIGER XC, TIGER XCa, TIGER XCx	2015 ON	BRIDGESTONE PIRELLI MICHELIN	BATTLE WING BW-501 SCORPION TRAIL ANAKEE 3	G STANDARD STANDARD	90/90-21 54 Q 90/90-21 54 Q 90/90-21 54 Q	2.48 bar (36 lb/in ²)	BATTLE WING BW-502 SCORPION TRAIL ANAKEE 3	G G STANDARD	150/70/R17 69 V 150/70/R17 69 V 150/70/R17 69 V	2.90 bar (42 lb/in ²)
TIGER XC, TIGER XCa, TIGER XCx DUAL PURPOSE TIRES (APPROVED BY TRIUMPH FOR OFF ROAD AND ON ROAD USE IN SOME COUNTRIES ONLY). THE PERMISSABLE MAXIMUM SPEED FOR DUAL PURPOSE TIRES IS 60 MPH (96 KM/H).	2015 ON	METZELER	KAROO 3	STANDARD	90/90-21 54 Q	2.48 bar (36 lb/in ²)	KAROO 3	STANDARD	150/70/R17 69 V	2.90 bar (42 lb/in ²)
TIGER EXPLORER AND TIGER EXPLORER XC (UP TO VIN 740276)	2012 ON	METZELER PIRELLI BRIDGESTONE	TOURANCE EXP SCORPION TRAIL BATTLE WING BW-501	STANDARD STANDARD STANDARD	110/80/R19 59 V 110/80/R19 59 V 110/80/R19 59 V	2.48 bar (36 lb/in ²)	TOURANCE EXP SCORPION TRAIL BATTLE WING BW-502	STANDARD STANDARD STANDARD	150/70/R17 69 V 150/70/R17 69 V 150/70/R17 69 V	2.90 bar (42 lb/in ²)
TIGER EXPLORER XC AND TIGER EXPLORER XR - ALL MODELS (FROM VIN 740277)	2016 ON	METZELER CONTINENTAL MICHELIN	TOURANCE NEXT TRAIL ATTACK 2 ANAKEE 3	E STANDARD STANDARD	120/70/R19 60V 120/70/R19 60V 120/70/R19 60V	2.20 bar (32 lb/in ²)	TOURANCE NEXT TRAIL ATTACK 2 ANAKEE 3	E STANDARD STANDARD	170/60/R17 72V 170/60/R17 72V 170/60/R17 72V	2.69 bar (39 lb/in ²)
TIGER EXPLORER XC AND TIGER EXPLORER XR - ALL MODELS (FROM VIN 740277) DUAL PURPOSE TIRES (APPROVED BY TRIUMPH FOR OFF ROAD AND ON ROAD USE IN SOME COUNTRIES ONLY). THE PERMISSABLE MAXIMUM SPEED FOR DUAL PURPOSE TIRES IS 60 MPH (96 KM/H).	2016 ON	METZELER	KAROO 3	STANDARD	120/70/R19 60T	2.20 bar (32 lb/in ²)	KAROO 3	STANDARD	170/60/R17 72T	2.69 bar (39 lb/in ²)
TIGER SPORT (FROM VIN 570059 TO 741390)	2013 ON	PIRELLI METZELER DUNLOP MICHELIN	ANGEL ST ROADTEC Z8 INTERACT ROADSMART PILOT ROAD 3	A STANDARD STANDARD STANDARD	120/70/ZR17 58 W 120/70/ZR17 58 W 120/70/ZR17 58 W 120/70/ZR17 58 W	2.34 bar (34 lb/in ²)	ANGEL ST ROADTEC Z8 INTERACT ROADSMART PILOT ROAD 3	STANDARD STANDARD STANDARD STANDARD	180/55/ZR17 73 W 180/55/ZR17 73 W 180/55/ZR17 73 W 180/55/ZR17 73 W	2.90 bar (42 lb/in ²)
TIGER SPORT (FROM VIN 750470)	2016 ON	PIRELLI PIRELLI PIRELLI DUNLOP	ANGEL ST ANGEL GT SCORPION TRAIL 2 ROADSMART	A A STANDARD STANDARD	120/70/ZR17 58 W 120/70/ZR17 58 W 120/70/ZR17 58 W 120/70/ZR17 58 W	2.34 bar (34 lb/in ²)	ANGEL ST ANGEL GT SCORPION TRAIL 2 ROADSMART	STANDARD STANDARD STANDARD STANDARD	180/55/ZR17 73 W 180/55/ZR17 73 W 180/55/ZR17 73 W 180/55/ZR17 73 W	2.90 bar (42 lb/in ²)

Back...

Classics

Index

MODEL	MODEL YEAR	MANUFACTURER	FRONT TIRE	SPECIFICATION	SIZE	PRESSURE	REAR TIRE	SPECIFICATION	SIZE	PRESSURE
THUNDERBIRD	1995 TO 1998 1995 ON 1995 TO 1998 1999 ON 1999 ON	MICHELIN AVON DUNLOP MICHELIN PIRELLI	A89X AV27 K105F MACADAM 90X MTR03		110/80/ZR18 110/80-18 58 H 110/80-18 110/80-18 110/80/ZR18 58 W	2.48 bar (36 lb/in ²)	M89X ELAN II RL30 K700J MACADAM 90X MTR04		160/80/ZR16 160/80-16 75 H 150/80-16 150/80-16 150/80/ZR16 71 W	2.90 bar (42 lb/in ²)
ADVENTURER (UP TO VIN 71698)	1996 TO 1998	AVON MICHELIN DUNLOP	AV27 A89X K105F		110/80-18 110/80-18 110/80-18	2.48 bar (36 lb/in ²)	ELAN II RL30 M89X K700J		160/80-16 160/80-16 160/80-16	2.90 bar (42 lb/in ²)
ADVENTURER (FROM VIN 71699)	1999 ON	MICHELIN METZELER	MACADAM 50 ME 33		100/90-19 100/90-19	2.48 bar (36 lb/in ²)	MACADAM 50 ME Z2		150/80-16 150/80-16	2.90 bar (42 lb/in ²)
THUNDERBIRD SPORT	1998 TO 1999 1998 TO 1999 2000 ON 2000 ON	AVON PIRELLI PIRELLI METZELER	AV27 DRAGON GT MTR23 ME Z4B		120/70/R17 120/70/R17 120/70-17 120/70-17	2.48 bar (36 lb/in ²)	AV281 DRAGON GT MTR24 ME Z4		160/70/R17 160/70/R17 160/70-17 160/70-17	2.90 bar (42 lb/in ²)
LEGEND TT	1999 ON	BRIDGESTONE MICHELIN MICHELIN	BT57 M90X MACADAM		120/70-17 120/70-17 120/70-17	2.48 bar (36 lb/in ²)	BT57 M90X MACADAM		160/60-17 160/60-17 160/60-17	2.90 bar (42 lb/in ²)
BONNEVILLE (CARBURETTOR MODELS)	2001 ON	BRIDGESTONE METZELER	BT45 F ME 33 LASER		100/90-19 100/90-19	2.27 bar (33 lb/in ²)	BT45 R ME Z2		130/80-17 130/80/R17	2.62 bar (38 lb/in ²)
BONNEVILLE T100 (CARBURETTOR MODELS)	2001 ON	METZELER	ME 33 LASER		100/90-19	2.27 bar (33 lb/in ²)	ME Z2		130/80/R17	2.62 bar (38 lb/in ²)
SCRAMBLER (CARBURETTOR MODELS)	2006 ON	BRIDGESTONE	TW 101		100/90-19	2.07 bar (30 lb/in ²)	TW 42		130/80-17	2.34 bar (34 lb/in ²)
THRUXTON (CARBURETTOR MODELS)	2005 ON	METZELER	LASERTEC		100/90-18	2.27 bar (33 lb/in ²)	ME Z2		130/80/R17	2.62 bar (38 lb/in ²)
BONNEVILLE (EFI MODELS)	2008 TO 2009	METZELER	LASERTEC		100/90-19	2.27 bar (33 lb/in ²)	ME Z2		130/80/R17	2.83 bar (41 lb/in ²)
BONNEVILLE (EFI MODELS)	2009 ON	METZELER	ME Z4	STANDARD	110/70/R17 54 H	2.27 bar (33 lb/in ²)	ME Z2	STANDARD	130/80/R17 65 H	2.83 bar (41 lb/in ²)
BONNEVILLE T100 (EFI MODELS) INCLUDING STEVE MCQUEEN™ EDITION AND BONNEVILLE 110 TH EDITION	2008 ON	METZELER	LASERTEC	STANDARD	100/90-19 57 H	2.27 bar (33 lb/in ²)	ME Z2	STANDARD	130/80/R17 65 H	2.83 bar (41 lb/in ²)
SCRAMBLER (EFI MODELS)	2008 ON	BRIDGESTONE	TRAIL WING TW-101	STANDARD	100/90-19 57 H	2.07 bar (30 lb/in ²)	TRAIL WING TW-42	STANDARD	130/80-17 65 H	2.83 bar (41 lb/in ²)
THRUXTON (EFI MODELS)	2008 ON	METZELER	LASERTEC STANDARD	STANDARD	100/90-18 56 H	2.27 bar (33 lb/in ²)	ME Z2	STANDARD	130/80/R17 65 H	2.83 bar (41 lb/in ²)

Continued...

Classics (continued)

Index

MODEL	MODEL YEAR	MANUFACTURER	FRONT TIRE	SPECIFICATION	SIZE	PRESSURE	REAR TIRE	SPECIFICATION	SIZE	PRESSURE
STREET TWIN	2016 ON	PIRELLI AVON	PHANTOM SPORTCOMP STORM 3D X-M	STANDARD STANDARD	100/90-18 56 H 100/90 R18 56 V	2.20 bar (32 lb/in ²)	PHANTOM SPORTCOMP STORM 3D X-M	STANDARD STANDARD	150/70 R17 69 H 150/70 R17 69 V	2.48 bar (36 lb/in ²)
BONNEVILLE T120	2016 ON	PIRELLI AVON	PHANTOM SPORTCOMP STORM 3D X-M	STANDARD STANDARD	100/90-18 56 H 100/90 R18 56 V	2.20 bar (32 lb/in ²)	PHANTOM SPORTCOMP STORM 3D X-M	STANDARD STANDARD	150/70 R17 69 H 150/70 R17 69 V	2.48 bar (36 lb/in ²)
THRUXTON	2016 ON	METZELER	SPORTEC M7 RR	STANDARD	120/70 ZR17 58 W	2.48 bar (36 lb/in ²)	SPORTEC M7 RR	STANDARD	160/60 ZR17 69 W	2.48 bar (36 lb/in ²)
THRUXTON R	2016 ON	PIRELLI	DIABLO ROSSO CORSA	STANDARD	120/70 ZR17 58 W	2.48 bar (36 lb/in ²)	DIABLO ROSSO CORSA	STANDARD	160/60 ZR17 69 W	2.48 bar (36 lb/in ²)

[Back...](#)

Cruisers

Index

MODEL	MODEL YEAR	MANUFACTURER	FRONT TIRE	SPECIFICATION	SIZE	PRESSURE	REAR TIRE	SPECIFICATION	SIZE	PRESSURE
AMERICA (CARBURETTOR MODELS)	2002 ON	BRIDGESTONE METZELER	L303 LAZERTEC		3.50-18 110/80-18	SOLO - 2.06 bar (30 lb/in ²) LADEN - 2.13 bar (31 lb/in ²)	G456 ME880		170/80-15 170/80/B15	SOLO - 2.13 bar (31 lb/in ²) LADEN - 2.50 bar (36 lb/in ²)
SPEEDMASTER 790 CC (CARBURETTOR MODELS)	2003 ON	METZELER	LAZERTEC		110/80-18	SOLO - 2.06 bar (30 lb/in ²) LADEN - 2.13 bar (31 lb/in ²)	ME880		170/80/B15	SOLO - 2.13 bar (31 lb/in ²) LADEN - 2.50 bar (36 lb/in ²)
SPEEDMASTER 865 CC (CARBURETTOR MODELS)	2004 TO 2008	METZELER	LASERTEC		110/90-18	SOLO - 2.06 bar (30 lb/in ²) LADEN - 2.13 bar (31 lb/in ²)	ME880		170/80/B15	SOLO - 2.13 bar (31 lb/in ²) LADEN - 2.50 bar (36 lb/in ²)
AMERICA (EFI MODELS)	2008 TO 2011	METZELER	LASERTEC	STANDARD	110/90-18 61 H	2.48 bar (36 lb/in ²)	ME880 MARATHON	STANDARD	170/80-15 77 H	2.90 bar (42 lb/in ²)
AMERICA (EFI MODELS)	2011 ON	METZELER	ME880 MARATHON	STANDARD	130/90-16 67 H	2.06 bar (30 lb/in ²)	ME880 MARATHON	STANDARD	170/80/B15 77 H	2.90 bar (42 lb/in ²)
SPEEDMASTER (EFI MODELS)	2008 TO 2011	METZELER	LASERTEC	STANDARD	110/80-18 61 H	2.48 bar (36 lb/in ²)	ME880 MARATHON	STANDARD	170/80-15 77 H	2.90 bar (42 lb/in ²)
SPEEDMASTER (EFI MODELS)	2011 ON	METZELER	ME880 MARATHON	STANDARD	100/90-19 57 H	2.48 bar (36 lb/in ²)	ME880 MARATHON	STANDARD	170/80/B15 77 H	2.90 bar (42 lb/in ²)
ROCKET III	2005 TO 2010	METZELER	ME880 MARATHON	STANDARD	150/80/R17 72 V	2.48 bar (36 lb/in ²)	ME880 MARATHON	STANDARD	240/50/R16 77 V	2.90 bar (42 lb/in ²)
ROCKET III TOURING	2008 ON	METZELER	ME880 MARATHON	STANDARD	150/80/R16 71 V	2.48 bar (36 lb/in ²)	ME880 MARATHON	STANDARD	180/70/R16 V	2.90 bar (42 lb/in ²)
ROCKET III ROADSTER	2010 ON	METZELER	ME880 MARATHON	STANDARD	150/80/R17 72 V	2.34 bar (34 lb/in ²)	ME880 MARATHON	STANDARD	240/50/R16 84 V	2.90 bar (42 lb/in ²)
THUNDERBIRD AND THUNDERBIRD STORM / NIGHT STORM	2009 ON	METZELER DUNLOP	ME880 MARATHON SPORTMAX D208	STANDARD STANDARD	120/70/R19 60 W 120/70/R19 60 W	2.48 bar (36 lb/in ²)	ME880 MARATHON SPORTMAX D208	STANDARD STANDARD	200/50/R17 75 W 200/50/R17 75 W	2.62 bar (38 lb/in ²)
THUNDERBIRD COMMANDER	2014 ON	METZELER	ME880 MARATHON	STANDARD	140/75/R17 67 W	2.48 bar (36 lb/in ²)	ME880 MARATHON	STANDARD	200/50/R17 75 W	2.62 bar (38 lb/in ²)
THUNDERBIRD LT	2014 ON	AVON METZELER	COBRA WHITEWALL ME880 MARATHON	STANDARD STANDARD	150/80/R16 71 H 150/80/R16 71 H	2.48 bar (36 lb/in ²) 2.68 bar (39 lb/in ²)	COBRA WHITEWALL ME880 MARATHON	STANDARD STANDARD	180/70/R16 77 H 180/70/R16 77 H	3.00 bar (44 lb/in ²) 2.90 bar (42 lb/in ²)

Roadsters

Index

MODEL	MODEL YEAR	MANUFACTURER	FRONT TIRE	SPECIFICATION	SIZE	PRESSURE	REAR TIRE	SPECIFICATION	SIZE	PRESSURE
SPEED TRIPLE 900 CC	1994 ON 1994 ON 1994 TO 1995 1995 ON 1996 1994 TO 1996 1994 TO 1996 1994 TO 1996 1994 TO 1996	MICHELIN BRIDGESTONE MICHELIN DUNLOP MICHELIN PIRELLI METZELER PIRELLI METZELER	TX11 BT50F TX11 D203 SPORTMAX TX15 MTR01 CORSA ME Z12 MTR01 ME Z1		120/70-17 120/70-17 120/70-17 120/70-17 120/70-17 120/70-17 120/70-17 120/70-17 120/70-17	2.20 bar (32 lb/in ²)	TX23A BT50 RADIAL G TX23B D203 SPORTMAX TX25 MTR02 CORSA ME Z1R MTR02 ME Z1		180/55-17 180/55-17 180/55-17 180/55-17 180/55-17 180/55-17 180/55-17 180/55-17 180/55-17	2.62 bar (38 lb/in ²)
SPEED TRIPLE 750 CC	1996 TO 1997	MICHELIN PIRELLI	90X MTR03 DRAGON GT		120/70-17 120/70-17	2.20 bar (32 lb/in ²)	90X MTR04 DRAGON GT		160/60-18 160/60-18	2.62 bar (38 lb/in ²)
TRIDENT 750 CC AND 900 CC	1991 TO 1995 1991 ON 1991 ON 1993 ON	DUNLOP MICHELIN PIRELLI BRIDGESTONE MICHELIN	K455F A59X MTR03 DRAGON GT BT50F 90X		120/70-17 120/70-17 120/70-17 120/70-17 120/70-17	2.48 bar (36 lb/in ²)	K455A M59X MTR04 DRAGON GT BT50R 90X		160/80-18 160/80-18 160/80-18 160/80-18 160/80-18	2.83 bar (41 lb/in ²)
SPEED TRIPLE 885 CC AND 955 CC (UP TO VIN 141871)	1997 ON	BRIDGESTONE MICHELIN METZELER	BT56 TX15 HI SPORT RCG		120/70-17 120/70-17 120/70-17	2.20 bar (32 lb/in ²)	BT56 TX25 HI SPORT RCG		190/50-17 190/50-17 190/50-17	2.90 bar (42 lb/in ²)
SPEED TRIPLE 955 CC (FROM VIN 141872 UP TO VIN 210444)	2002 ON	BRIDGESTONE PIRELLI METZELER	BT010 DRAGON EVO ME Z3		120/70-17 120/70-17 120/70-17	2.20 bar (32 lb/in ²)	BT010 DRAGON EVO ME23		190/50-17 190/50-17 190/50-17	2.90 bar (42 lb/in ²)
SPEED FOUR	2002 ON	BRIDGESTONE MICHELIN PIRELLI	BT010 PILOT SPORT DRAGON EVO		120/70/R17 120/70/R17 120/70/R17	2.34 bar (34 lb/in ²)	BT010 PILOT SPORT DRAGON EVO		180/55/R17 180/55/R17 180/55/R17	2.62 bar (38 lb/in ²)
SPEED TRIPLE 1050 CC (FROM VIN 210445 UP TO VIN 332110)	2005 TO 2009	MICHELIN BRIDGESTONE	PILOT POWER BT14		120/70/ZR17 120/70/ZR17	2.34 bar (34 lb/in ²)	PILOT POWER BT14		180/55/ZR17 180/55/ZR17	2.90 bar (42 lb/in ²)
SPEED TRIPLE 1050 CC (FROM VIN 332110 UP TO VIN 461331)	2009 TO 2011	METZELER DUNLOP BRIDGESTONE BRIDGESTONE	SPORTEC M3 SPORTMAX QUALIFIER BATTLAX BT-015 BATTLAX BT-016	C STANDARD G STANDARD	120/70/ZR17 58 W 120/70/ZR17 58 W 120/70/ZR17 58 W 120/70/ZR17 58 W	2.34 bar (34 lb/in ²)	SPORTEC M3 SPORTMAX QUALIFIER BATTLAX BT-015 BATTLAX BT-016	STANDARD STANDARD E STANDARD	180/55/ZR17 73 W 180/55/ZR17 73 W 180/55/ZR17 73 W 180/55/ZR17 73 W	2.90 bar (42 lb/in ²)
SPEED TRIPLE 1050 CC (FROM VIN 461332 UP TO VIN 733009)	2011 ON	METZELER BRIDGESTONE BRIDGESTONE PIRELLI MICHELIN MICHELIN	RACETEC INTERACT K3 BATTLAX BT-003 RACING STREET BATTLAX BT-016 DIABLO ROSSO CORSA POWER PURE PILOT ROAD 2	STANDARD STANDARD STANDARD STANDARD STANDARD STANDARD	120/70/ZR17 58 W 120/70/ZR17 58 W 120/70/ZR17 58 W 120/70/ZR17 58 W 120/70/ZR17 58 W 120/70/ZR17 58 W	2.34 bar (34 lb/in ²)	RACETEC INTERACT K3 BATTLAX BT-003 RACING STREET BATTLAX BT-016 DIABLO ROSSO CORSA POWER PURE PILOT ROAD 2	STANDARD STANDARD STANDARD STANDARD STANDARD STANDARD	190/55/ZR17 75 W 190/55/ZR17 75 W 190/55/ZR17 75 W 190/55/ZR17 75 W 190/55/ZR17 75 W 190/55/ZR17 75 W	2.90 bar (42 lb/in ²)
SPEED TRIPLE R 1050 CC (UP TO VIN 733009)	2012 ON 2012 ON 2012 ON 2013 ON	METZELER BRIDGESTONE MICHELIN PIRELLI PIRELLI	RACETEC INTERACT K3 BATTLAX BT-016 PILOT ROAD 2 RACETEC INTERACT K3 DIABLO SUPERCORSA SP	STANDARD STANDARD STANDARD STANDARD STANDARD	120/70/ZR17 58 W 120/70/ZR17 58 W 120/70/ZR17 58 W 120/70/ZR17 58 W 120/70/ZR17 58 W	2.34 bar (34 lb/in ²)	RACETEC INTERACT K3 BATTLAX BT-016 PILOT ROAD 2 RACETEC INTERACT K3 DIABLO SUPERCORSA SP	STANDARD STANDARD STANDARD STANDARD STANDARD	190/55/ZR17 75 W 190/55/ZR17 75 W 190/55/ZR17 75 W 190/55/ZR17 75 W 190/55/ZR17 75 W	2.90 bar (42 lb/in ²)
SPEED TRIPLE S AND SPEED TRIPLE R (FROM VIN 735337)	2016 ON	PIRELLI PIRELLI METZELER MICHELIN	DIABLO SUPERCORSA SP DIABLO ROSSO CORSA SPORTEC M7 RR PILOT ROAD 3	STANDARD STANDARD M STANDARD	120/70/ZR17 58 W 120/70/ZR17 58 W 120/70/ZR17 58 W 120/70/ZR17 58 W	2.34 bar (34 lb/in ²)	DIABLO SUPERCORSA SP DIABLO ROSSO CORSA SPORTEC M7 RR PILOT ROAD 3	STANDARD STANDARD STANDARD STANDARD	190/55/ZR17 75 W 190/55/ZR17 75 W 190/55/ZR17 75 W 190/55/ZR17 75 W	2.90 bar (42 lb/in ²)

Continued...

Roadsters (continued)

Index

MODEL	MODEL YEAR	MANUFACTURER	FRONT TIRE	SPECIFICATION	SIZE	PRESSURE	REAR TIRE	SPECIFICATION	SIZE	PRESSURE
STREET TRIPLE (UP TO VIN 459241)	2007 TO 2009 2007 TO 2009 2007 TO 2009	BRIDGESTONE BRIDGESTONE DUNLOP	BATTLAX BT-016 BATTLAX BT-015 SPORTMAX QUALIFIER	STANDARD G STANDARD	120/70/ZR17 58 W 120/70/ZR17 58 W 120/70/ZR17 58 W	2.34 bar (34 lb/in ²)	BATTLAX BT-016 BATTLAX BT-015 SPORTMAX QUALIFIER	STANDARD E STANDARD	180/55/ZR17 73 W 180/55/ZR17 73 W 180/55/ZR17 73 W	2.90 bar (42 lb/in ²)
STREET TRIPLE (FROM VIN 459241 UP TO VIN 560476)	2012 TO 2013 2010 TO 2013 2010 TO 2013 2012 TO 2013	BRIDGESTONE PIRELLI METZELER DUNLOP	BATTLAX BT-016 DIABLO ROSSO CORSA SPORTEC M3 SPORTMAX QUALIFIER	STANDARD K C STANDARD	120/70/ZR17 58 W 120/70/ZR17 58 W 120/70/ZR17 58 W 120/70/ZR17 58 W	2.34 bar (34 lb/in ²)	BATTLAX BT-016 DIABLO ROSSO CORSA SPORTEC M3 SPORTMAX QUALIFIER	STANDARD STANDARD STANDARD STANDARD	180/55/ZR17 73 W 180/55/ZR17 73 W 180/55/ZR17 73 W 180/55/ZR17 73 W	2.90 bar (42 lb/in ²)
STREET TRIPLE R (UP TO VIN 452037)	2007 TO 2009	DUNLOP	SPORTMAX QUALIFIER	STANDARD	120/70/ZR17 58 W	2.34 bar (34 lb/in ²)	DUNLOP	STANDARD	180/55/ZR17 73 W	2.90 bar (42 lb/in ²)
STREET TRIPLE R (FROM VIN 452037 UP TO VIN 560477)	2009 TO 2013 2012 TO 2013 2012 TO 2013 2012 TO 2013	DUNLOP PIRELLI BRIDGESTONE PIRELLI	SPORTMAX QUALIFIER DIABLO ROSSO CORSA BATTLAX BT-016 DRAGON SUPERCORSA PRO	STANDARD STANDARD STANDARD STANDARD	120/70/ZR17 58 W 120/70/ZR17 58 W 120/70/ZR17 58 W 120/70/ZR17 58 W	2.34 bar (34 lb/in ²)	SPORTMAX QUALIFIER DIABLO ROSSO CORSA BATTLAX BT-016 DRAGON SUPERCORSA PRO	STANDARD STANDARD STANDARD STANDARD	180/55/ZR17 73 W 180/55/ZR17 73 W 180/55/ZR17 73 W 180/55/ZR17 73 W	2.90 bar (42 lb/in ²)
STREET TRIPLE AND STREET TRIPLE R (FROM VIN 560477) STREET TRIPLE Rx	2013 ON	PIRELLI METZELER DUNLOP BRIDGESTONE	DIABLO ROSSO CORSA SPORTEC M5 INTERACT SPORTMAX QUALIFIER II BATTLAX BT-016 PRO	STANDARD STANDARD STANDARD STANDARD	120/70/ZR17 58 W 120/70/ZR17 58 W 120/70/ZR17 58 W 120/70/ZR17 58 W	2.34 bar (34 lb/in ²)	DIABLO ROSSO CORSA SPORTEC M5 INTERACT SPORTMAX QUALIFIER II BATTLAX BT-016 PRO	STANDARD STANDARD STANDARD STANDARD	180/55/ZR17 73 W 180/55/ZR17 73 W 180/55/ZR17 73 W 180/55/ZR17 73 W	2.90 bar (42 lb/in ²)

[Back...](#)

Supersports

Index

MODEL	MODEL YEAR	MANUFACTURER	FRONT TIRE	SPECIFICATION	SIZE	PRESSURE	REAR TIRE	SPECIFICATION	SIZE	PRESSURE
DAYTONA 750 AND DAYTONA 1000	1991 TO 1992	MICHELIN DUNLOP	TX11 K455F		120/70-17 120/70-17	2.48 bar (36 lb/in ²)	TX23 K455A		160/60-18 160/60-18	2.83 bar (41 lb/in ²)
DAYTONA 900 AND DAYTONA 1200	1993 1994 ON 1993 1994 1994 TO 1995 1994 TO 1995 1995 ON 1995 1995 1995 1996 ON 1996 ON	BRIDGESTONE BRIDGESTONE DUNLOP MICHELIN MICHELIN DUNLOP MICHELIN PIRELLI PIRELLI METZELER MICHELIN METZELER	BT50F BT50F K455FG TX11 TX11 D364 TX11A MTR01 MTR01 CORSA ME Z1F TX15 ME Z1R		120/70-17 120/70-17 120/70-17 120/70-17 120/70-17 120/70-17 120/70-17 120/70-17 120/70-17 120/70-17 120/70-17 120/70-17	2.48 bar (36 lb/in ²)	BT50R BT50R RADIAL G K455A TX23A TX23B D364 TX23A MTR02 MTR02 CORSA ME Z1 TX25 ME Z1R		160/60-18 180/55-17 160/60-18 180/55-17 180/55-17 180/55-17 180/55-17 180/55-17 180/55-17 180/55-17 180/55-17 180/55-17	2.83 bar (41 lb/in ²)
SUPER III	1994 TO 1995 1994 ON 1994 ON 1994 TO 1995 1995 1995 ON 1995 1996 1996	DUNLOP BRIDGESTONE MICHELIN MICHELIN PIRELLI PIRELLI METZELER MICHELIN METZELER	D364 BT50F TX11 TX11 MTR01 MTR01 CORSA ME Z1F TX15 ME Z1R		120/70-17 120/70-17 120/70-17 120/70-17 120/70-17 120/70-17 120/70-17 120/70-17 120/70-17	2.48 bar (36 lb/in ²)	D364 BT50 RADIAL G TX23A TX23B MTR02 MTR02 CORSA ME Z1 TX25 ME Z1R		180/55-17 180/55-17 180/55-17 180/55-17 180/55-17 180/55-17 180/55-17 180/55-17 180/55-17	2.83 bar (41 lb/in ²)
DAYTONA 955i (UP TO VIN 132512)	1997 ON	BRIDGESTONE MICHELIN METZELER MICHELIN PIRELLI	BT56 TX15 HI SPORT RCG TX15 MTR01 CORSA		120/70-17 120/70-17 120/70-17 120/70-17 120/70-17	2.48 bar (36 lb/in ²)	BT56 TX25 HI SPORT RCG TX25 MTR02 CORSA		190/50-17 190/50-17 190/50-17 190/50-17 190/50-17	2.90 bar (42 lb/in ²)
DAYTONA 955i - DOUBLE SIDED SWINGING ARM (FROM VIN 132513)	2001 ON	BRIDGESTONE MICHELIN PIRELLI METZELER	BT010 PILOT SPORT DRAGON EVO ME Z3		120/70-17 120/70-17 120/70-17 120/70-17	2.20 bar (32 lb/in ²)	BT010 PILOT SPORT DRAGON EVO ME Z3		180/55-17 180/55-17 180/55-17 180/55-17	2.62 bar (38 lb/in ²)
DAYTONA 955i - SINGLE SIDED SWINGING ARM (FROM VIN 132513)	2002 ON	BRIDGESTONE PIRELLI METZELER	BT010 DRAGON EVO ME23		120/70-17 120/70-17 120/70-17	2.48 bar (36 lb/in ²)	BT010 DRAGON EVO ME23		190/50-17 190/50-17 190/50-17	2.90 bar (42 lb/in ²)
TT600	2000 ON	BRIDGESTONE MICHELIN PIRELLI	BT010 PILOT SPORT DRAGON EVO		120/70/R17 120/70/R17 120/70/R17	2.34 bar (34 lb/in ²)	BT010 PILOT SPORT DRAGON EVO		180/55/R17 180/55/R17 180/55/R17	2.62 bar (38 lb/in ²)
DAYTONA 600 AND 650	2004 ON	PIRELLI BRIDGESTONE METZELER MICHELIN	DIABLO T BT012 SPORTEC M1 PILOT SPORT		120/70/ZR17 58 W 120/70/R17 120/70/R17 120/70/ZR17	2.34 bar (34 lb/in ²)	DIABLO T BT012 SPORTEC M1 PILOT SPORT		180/55/ZR17 73 W 180/55/R17 180/55/R17 180/55/ZR17	2.62 bar (38 lb/in ²)
DAYTONA 675 (UP TO VIN 381274)	2006 TO 2009	PIRELLI MICHELIN BRIDGESTONE	DRAGON SUPERCORSA PRO PILOT POWER B BT014 G		120/70/ZR17 120/70/ZR17 120/70/ZR17	2.34 bar (34 lb/in ²)	DRAGON SUPERCORSA PRO PILOT POWER B BT014 G		180/55/ZR17 180/55/ZR17 180/55/ZR17	2.48 bar (36 lb/in ²)
DAYTONA 675 AND DAYTONA 675R (FROM VIN 381275 UP TO 564947)	2009 TO 2013	PIRELLI DUNLOP METZELER	DIABLO SUPERCORSA SP SPORTMAX QUALIFIER SPORTEC M3	STANDARD STANDARD C	120/70/ZR17 58 W 120/70/ZR17 58 W 120/70/ZR17 58 W	2.34 bar (34 lb/in ²)	DIABLO SUPERCORSA SP SPORTMAX QUALIFIER SPORTEC M3	STANDARD STANDARD STANDARD	180/55/ZR17 73 W 180/55/ZR17 73 W 180/55/ZR17 73 W	2.48 bar (36 lb/in ²)
DAYTONA 675 AND DAYTONA 675R (FROM VIN 564948)	2013 ON	PIRELLI METZELER PIRELLI BRIDGESTONE	DIABLO SUPERCORSA SP RACETEC INTERACT K3 DIABLO ROSSO CORSA BATTLAX BT-016 PRO	STANDARD STANDARD STANDARD STANDARD	120/70/ZR17 58 W 120/70/ZR17 58 W 120/70/ZR17 58 W 120/70/ZR17 58 W	2.34 bar (34 lb/in ²)	DIABLO SUPERCORSA SP RACETEC INTERACT K3 DIABLO ROSSO CORSA BATTLAX BT-016 PRO	STANDARD STANDARD STANDARD STANDARD	180/55/ZR17 73 W 180/55/ZR17 73 W 180/55/ZR17 73 W 180/55/ZR17 73 W	2.48 bar (36 lb/in ²)

Touring

Index

MODEL	MODEL YEAR	MANUFACTURER	FRONT TIRE	SPECIFICATION	SIZE	PRESSURE	REAR TIRE	SPECIFICATION	SIZE	PRESSURE
SPRINT, SPRINT SPORT AND SPRINT EXECUTIVE	1993 TO 1994 1993 TO 1994 1993 TO 1994 1993 TO 1994 1993 TO 1994 1995 TO 1998 1995 TO 1998 1995 TO 1998 1995 1996 TO 1998 1996 TO 1998 1996 TO 1998	BRIDGESTONE DUNLOP MICHELIN PIRELLI MICHELIN DUNLOP BRIDGESTONE PIRELLI METZELER BRIDGESTONE METZELER MICHELIN	BT50F K455FG A59X MTR03 DRAGON GT 90X D202J BT54F MTR03 ME Z1F BT57F ME Z2 MACADAM 90X		120/70-17 120/70-17 120/70-17 120/70/ZR17 120/70-17 120/70-17 120/70-17 120/70-17 120/70-17 120/70-17 120/70-17 120/70-17	2.48 bar (36 lb/in ²)	BT50R K455A M59X MTR04 DRAGON GT 90X D202G BT54R MTR04 ME Z2 BT57R ME Z2 MACADAM 90X		160/80-18 160/80-18 160/80-18 170/60/ZR17 160/80-18 170/60-17 170/60-17 170/60-17 170/60-17 170/60-17 170/60-17 170/60-17	2.83 bar (41 lb/in ²)
TROPHY 900 AND 1200	1991 TO 1993 1991 TO 1992 1991 TO 1993 1993 1994 TO 1995 1994 1995 ON 1995 ON 1995 ON 1996	DUNLOP METZELER MICHELIN BRIDGESTONE DUNLOP MICHELIN BRIDGESTONE PIRELLI METZELER MICHELIN	K455A ME1 MBS A59X BT50F D202J A89X BT54F MTR03 DRAGON GT ME Z1F MACADAM 90X		120/70-17 120/70-17 120/70-17 120/70-17 120/70-17 120/70-17 120/70-17 120/70/ZR17 120/70-17 120/70-17	2.48 bar (36 lb/in ²)	K455A ME1 MBS M59X BT50R D202G A89X BT54R MTR04 DRAGON GT ME Z2 MACADAM 90X		160/60-18 160/60-18 160/60-18 160/60-18 170/60-17 170/60-17 170/60-17 170/60/ZR17 170/60-17 170/60-17	2.83 bar (41 lb/in ²)
SPRINT ST (UP TO VIN 139276)	1999 TO 2001	BRIDGESTONE MICHELIN	BT57G 90X		120/70-17 120/70-17	2.48 bar (36 lb/in ²)	BT57G 90X		180/55-17 180/55-17	2.83 bar (41 lb/in ²)
SPRINT RS (FROM VIN 139277)	2000 TO 2001	BRIDGESTONE MICHELIN BRIDGESTONE	BT020 90X BT57G		120/70-17 120/70-17 120/70-17	2.48 bar (36 lb/in ²)	BT020 90X BT57G		180/55-17 180/55-17 180/55-17	2.83 bar (41 lb/in ²)
SPRINT ST 955 CC (FROM VIN 139277 UP TO VIN 208166)	2002 ON	BRIDGESTONE BRIDGESTONE MICHELIN	BT57G BT010 100X		120/70-17 120/70-17 120/70-17	2.48 bar (36 lb/in ²)	BT57G BT010 100X		180/55-17 180/55-17 180/55-17	2.90 bar (42 lb/in ²)
SPRINT RS 955 CC (UP TO VIN 139277)	2002 TO 2003 2002 ON 2002 ON 2002 ON	BRIDGESTONE BRIDGESTONE MICHELIN BRIDGESTONE	BT020 BT010 100X BT57G		120/70-17 120/70-17 120/70-17 120/70-17	2.48 bar (36 lb/in ²)	BT020 BT010 100X BT57G		180/55-17 180/55-17 180/55-17 180/55-17	2.90 bar (42 lb/in ²)
SPRINT ST 1050 CC (UP TO VIN 139276)	2005 TO 2011	BRIDGESTONE BRIDGESTONE METZELER	BATTLAX BT-020 BATTLAX BT-020 ROADTEC Z6 INTERACT	STANDARD NN STANDARD	120/70/ZR17 58 W 120/70/ZR17 58 W 120/70/ZR17 58 W	2.48 bar (36 lb/in ²)	BATTLAX BT-020 BATTLAX BT-020 ROADTEC Z6 INTERACT	STANDARD NN C	180/55/ZR17 73 W 180/55/ZR17 73 W 180/55/ZR17 73 W	2.90 bar (42 lb/in ²)
SPRINT GT 1050 CC	2011 ON	BRIDGESTONE PIRELLI DUNLOP MICHELIN	BATTLAX BT-021 ANGEL ST SPORTMAX ROADSMART PILOT ROAD 2	FBZ A STANDARD D	120/70/ZR17 58 W 120/70/ZR17 58 W 120/70/ZR17 58 W 120/70/ZR17 58 W	2.48 bar (36 lb/in ²)	BATTLAX BT-021 ANGEL ST SPORTMAX ROADSMART PILOT ROAD 2	STANDARD E STANDARD B	180/55/ZR17 73 W 180/55/ZR17 73 W 180/55/ZR17 73 W 180/55/ZR17 73 W	2.90 bar (42 lb/in ²)
SPRINT ST 1050 CC (FROM VIN 139277)	2011 ON	BRIDGESTONE PIRELLI DUNLOP BRIDGESTONE	BATTLAX BT-021 ANGEL ST SPORTMAX ROADSMART BATTLAX BT-020	FBZ A STANDARD STANDARD	120/70/ZR17 58 W 120/70/ZR17 58 W 120/70/ZR17 58 W 120/70/ZR17 58 W	2.48 bar (36 lb/in ²)	BATTLAX BT-021 ANGEL ST SPORTMAX ROADSMART BATTLAX BT-020	FBZ E STANDARD U	180/55/ZR17 73 W 180/55/ZR17 73 W 180/55/ZR17 73 W 180/55/ZR17 73 W	2.90 bar (42 lb/in ²)
TROPHY AND TROPHY SE 1215 CC (FROM VIN 561284)	2013 ON	PIRELLI METZELER DUNLOP DUNLOP	ANGEL ST ROADTEC Z8 INTERACT SPORTMAX ROADSMART SPORTMAX ROADSMART II	A STANDARD STANDARD STANDARD	120/70/ZR17 58 W 120/70/ZR17 58 W 120/70/ZR17 58 W 120/70/ZR17 58 W	2.48 bar (36 lb/in ²)	ANGEL ST ROADTEC Z8 INTERACT SPORTMAX ROADSMART SPORTMAX ROADSMART II	STANDARD C K STANDARD	190/55/ZR17 75 W 190/55/ZR17 75 W 190/55/ZR17 75 W 190/55/ZR17 75 W	2.90 bar (42 lb/in ²)